



PATCH HANDLE BAG MAKING MACHINES

TAKVİYELİ POŞET KESME MAKİNALARI

FEATURES | ÖZELLİKLER

- Servo Motor and Invertor Control System.
- Bag length, Set Number Can be Changed Via Screen. Bag Counting, Machine Speed Can be Seen on the Screen.
- There is One Photocell. Ability to Produce Printed Bags and None-Printed Bags.
- Ability to Work With BOPP, OPP, PP, CPP, HDPE, LDPE Materials.
- The Machine Would Stop and Give Information on the Screen When, 'The Print Mark is Not in Right Position'.
- The Pneumatic Ballerina System With Motor and Invertor in Order to Unwind the Roll.
- The Synchronous Roller System.
- The Belt Motor Speed is Also Adjusted Via Invertor.
- The Rotating Lower Jaw is Included to the Machine as Standard.

- Servo Motor ve İnvörtör Sistemi
- Poşet Boyu, Poşet Sayısı Ekrandan Değiştirilir. Poşet Adedi Sayımı, Makine Hızı Ekrandan İzlenebilir.
- 1 Adet Fotosel Bulunur. Baskılı ve Baskısız Poşet Keser.
- BOPP, PP, OPP, CPP, Yüksek Yoğunluk Polietilen (HDPE), Alçak Yoğunluk Polietilen (LDPE) Poşetlerle Çalışabilme
- Rulo Bittiğinde, Baskı Doğru Yerde Olmadığında Makine Otomatik Olarak Durur ve Ekranda Bilgi Verir.
- Motorlu, Redüktörlü, İnvörtörlü ve Pnömatik Balerin Sistemi,
- Senkron Merdaneli
- Kayış Motoru Hızı İnvörtör İle Ayarlanır.
- Alt Çenede Döner Silikon Standart Özelliştir.

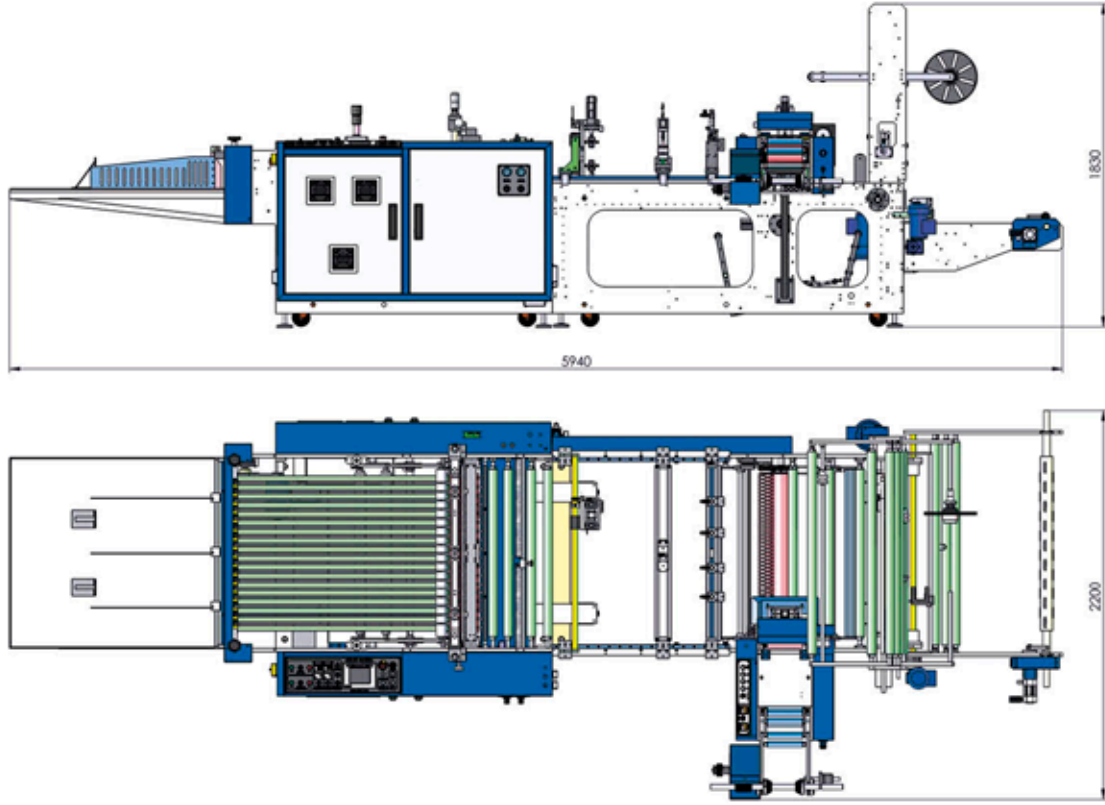

BAG TYPES | POŞET TIPLERİ

Standard | Standart



Optional | Opsiyonel

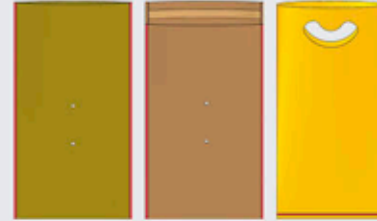

TECHNICAL SPECIFICATIONS | TEKNİK ÖZELLİKLER

| | | GM-700 ST | GM-900 ST | GM-1100 ST |
|---------------------------------------|-------------------------------------|---------------|---------------|---------------|
| Max. Bag Width (mm) | Maks. Poşet Genişliği (mm) | 650 | 850 | 1050 |
| Bag Length (mm) | Poşet Boyu (mm) | 80 - 2000 | 80 - 2000 | 80 - 2000 |
| Thickness of Film (mm) | Film Kalınlığı (mm) | 0,020 - 0,100 | 0,020 - 0,100 | 0,020 - 0,100 |
| Max. Production Speed (pieces/minute) | Maks. Üretim Hızı (adet/dakika) | 200 | 180 | 150 |
| • Patch Handle (pieces/minute) | Takviye (adet/dakika) | 80 | 80 | 80 |
| • Die Cut Handle (pieces/minute) | El Geçme (adet/dakika) | 100 | 100 | 100 |
| Total Air Consumption (liter/minute) | Toplam Hava Tüketimi (litre/dakika) | 200 | 250 | 300 |
| Total Installed Power (kW) | Toplam Güç (kW) | 9 | 9 | 9 |